

Fact Sheet

CWFmaxx 15000

BIZERBA

Our solution for food processing companies – dynamic checkweigher CWFmaxx was specially designed for this industry. Thanks to its sophisticated design it impresses in terms of hygiene and easy cleaning.



More information
High performance with a wide range of solutions and options.

Specifications	Facts	Details
Weighing data	Weighing range: 15,000 g	6,000 15,000 g
	Scale division d: 2-5 g	2 g 5 g
	Verification scale interval e: 2-5 g	2 g 5 g
	Minimum load: 500 g	500 g
Performance data	Max. throughput: 92-200 packages per min.	Depending on length of weighing conveyor
	Max. belt speed: 90 m/min	
	Min. belt speed: 5 m/min	
Device version / material	Stainless steel	1.4301
Operating panel	12" color touchscreen	
Interfaces	USB, EDP 1, 8 inputs, 8 outputs, Ethernet	EDP 1 (RS232 or RS422 or TTY)
IP rating	IP65	Conveying unit
		Control cabinet
		Display
Transport	Left to right right to left	Conveying direction
	750-1,150 mm	Transport height
Conveyor belt	Conveyor widths: 225-400 mm	225, 300, 400 mm
	Belt lengths:	Length specifications always as axle distance:
	Weighing conveyor length: 325-750 mm	325, 400, 500, 600, 750 mm
	Infeed conveyor length: 325-750 mm	325, 400, 500, 600, 750 mm
	Rejection conveyor length: 325-600 mm	325, 400, 500, 600 mm
	Belt colors: white and blue	white as a standard and blue optionally available
	Roll diameter: 32 mm	Rollers made of aluminum, surface hard coated
Belt unit and quick-change belt system		
Ambient conditions	0 °C to +40 °C	Operating temperature
	20 - 90%, non-condensing	Humidity
Energy supply	100-240 V, 50-60 Hz	Power supply
	500-750 VA	Power consumption
	6 bar	Compressed air supply
Software licenses	STATISTICS	To create statistics
	WEIGHT_CLASSES	For classification of more than 3 products
Software variants	Code page software	Data transfer (texts & strings)
	UNICODE software	Data transfer (texts & strings) in UTF-8 coding
further characteristics	Article memory	100,000
	Weight classes	80
	Remote maintenance	
	Web interface	
	Sending of status e-mails	

Options	Facts	Details
Metrologically approved as per OIML R 87	Prepack regulations (FPV) control	The checkweighers are metrologically approved as per accuracy class XIII (1) and therefore suitable for prepack regulations control.
Operating panel	7" color display with membrane keyboard	WVGA (800x480)
Indexing belt length	Upon request, handled as a project	
Rejection systems	Upon request, handled as a project	
Protocol printer	Mounted to control cabinet	Incl. license LINE_PRINTER and serial interface
Emergency stop	Emergency stop with belt switch-off Emergency stop with pneumatic system and belt switch-off	mounted to main column, turns off conveyor drives additionally switches off the pneumatic system
Signal lamp	2-color 3-color	Red = fault, green = device okay Red = fault, yellow = stop, green = belts running
Emergency operation function	The conveyor belts of the checkweighers can be started manually even if the operating and control unit failed.	The belts run in order to ensure the production flow (without weighing function). Operation via extra module in the control cabinet with adjustable belt speeds.
Tendency control kit	Incl. license Tendency Control and relay	
Line integration kit	3 outputs via relay and 1 input	
Flow control	Light sensor	
Guiding bars	available for all belt lengths	
Belt transition plates	available for all belt widths	closes the gaps between the belt bodies
Compressed air monitoring	stops the system when air pressure drops	
Software licenses	BRIDGE+MC_BUFFER VERIFIABLE_X1 ETHERNET ONLINE SOFTCONTROL TENDENCY CONTROL LINE_PRINTER	For buffering data in the event of LAN / pc failure as per prepack regulations, incl. conformity assessment Ethernet connection via TCP/IP Communication via Gx-Net via ETHERNET For operation from a second work station To regulate filling systems (without relay) Required for external printer

Info graphics

Symbols



200 packages per minute

IP65 protection

Unicode

e (metrologically approved)

Stainless steel

Strain gauge

Hygienic Design

Dimensional drawings

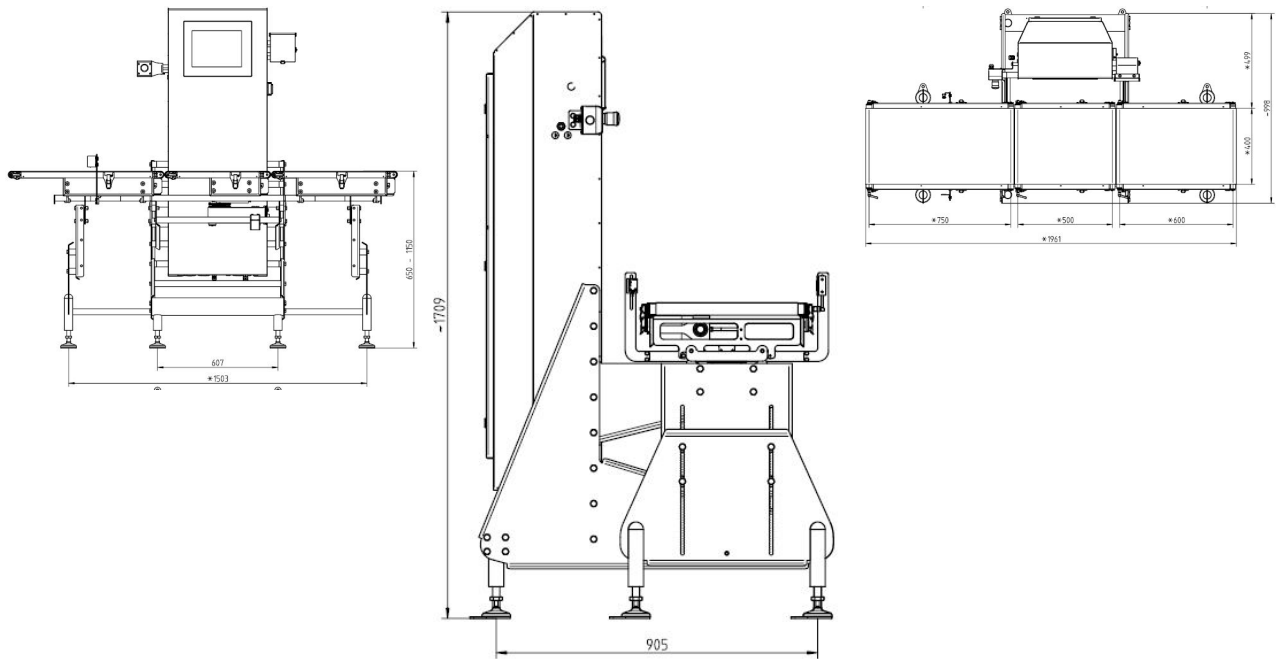

Bizerba SE & Co. KG
Wilhelm-Kraut-Straße 65
72336 Balingen

T +49 7433 12-0
fax: +49 7433 12-2696
marketing@bizerba.com

www.bizerba.com